

T100 & T60 Circular Pit

TRI TUFF[®] Collar Installation Instructions

The TRI TUFF Collar must be installed with a expansion joint foam roll to avoid excess compression from surrounding concrete when poured in situ

Step 1

Apply expansion joint foam roll

Fit adhesive backed 50x10mm expansion joint foam roll (with removable top strip) to the upper outer edge of the collar with removeable strip facing upwards.

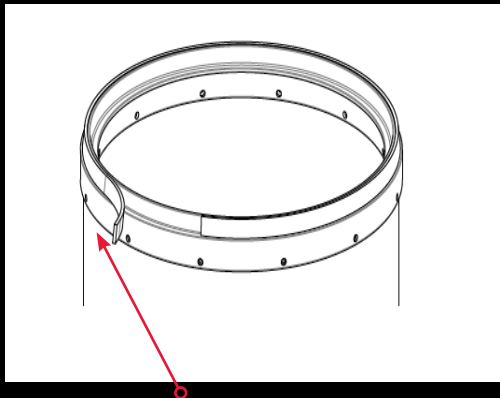

Step 2

After concrete is set

After concrete is set, remove the strip from the top of the expansion foam and seal joint between concrete and collar with non shrinking joint sealant.

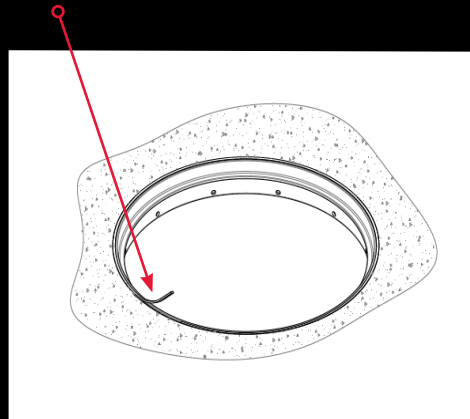

Step 3

Completion

Finish by ensuring the lid is in place and rubber cap is in the lid (for TRI TUFF lids only).

